

High Resolution BSI Scientific CMOS

Prime BSI delivers the perfect balance between high resolution imaging and sensitivity with an optimized pixel design and near perfect 95% Quantum Efficiency to maximize signal detection.

A 4 Megapixel camera with 6.5µm pixels, it captures highly detailed images with great quality while acquiring data at high frame rates. This ensures that all data is collected and no event goes undetected.

Prime BSI delivers a 100% pixel fill factor and does not rely on micro-lensing technology to increase detection, resulting in a 30% increase in sensitivity over previous sCMOS cameras.

This perfect balance in performance makes the Prime BSI the most versatile imaging camera for live-cell imaging with:

Primary applications:

TIRF Microscopy

Ratiometric Imaging

Cell Motility

Light Sheet Microscopy

- ▶ 95% Quantum Efficiency
- ▶ 6.5µm x 6.5µm Pixel Area
- ▶ 1.1e- Read Noise (median)
- ▶ 43.5 fps @ 16-bit
- ▶ PrimeEnhance increases SNR 3-5X

- ▶ Highest Sensitivity
- ▶ High Resolution
- ▶ Large Field of View
- ▶ High Frame Rates
- ▶ Large Dynamic Range

Features	Advantages
High Quantum Efficiency 95% Peak QE	Maximizes ability to detect weak signals, enables short exposure times for high frame rates, minimizes phototoxicity across a wide range of wavelengths
Optimized 6.5µm Pixel Size	Maximize light collection while maintaining proper spatial sampling at 60X
Extremely Low Read Noise	Maximize your ability to detect faint fluorescence
Fast Frame Rates	Capture highly dynamic events with high temporal resolution
Large Field of View	Maximize the number of cells that can be tracked and monitored per frame
PrimeEnhance™	Real-time quantitative denoising algorithm that improves image clarity by reducing photon-shot (Poisson) noise. Delivers an increase in Peak Signal to Noise Ratio of 3X to 5X
PrimeLocate™	Dynamically evaluates and acquires only the relevant data for localization based super-resolution applications
Enhanced Dynamic Range	Measure both bright and dim signal levels within the same image 41,000:1 Dynamic Range (92 dB)
Multiple Expose Out Triggering	Control up to four light sources for multi-wavelength acquisitions
SMART Streaming™	Faster acquisition rates with variable exposures, ideal for multi-probed live cell imaging Compatible with Multiple Expose Out Triggering



4.2 Megapixel BSI CMOS Sensor

- Backside Illuminated Sensor
- 1.1e- Read Noise (Median)
- >95% peak QE
- 45,000e- full well
- 6.5 x 6.5µm pixels
- 18.8mm diagonal

Easily Mounted and Secured

- C-mount
- Two ¼" -20 mounting holes per side

Convenient Interfaces

- 16-bit Data
 - 43.5 fps

Multiple Cooling Options

- Forced Air Cooling
 - -10°C Cooling
 - Selectable Fan Speed
- Liquid Cooling
 - -25°C Cooling
 - Leak-proof, quick-disconnect ports

Advanced Triggering Capabilities

- Effective Global Shutter
- Up to four selectable expose-out lines



Embedded Signal Processing (ESP™) Features

PrimeEnhance

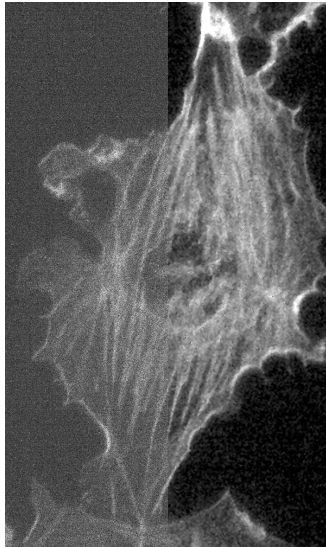

- ▶ Increase SNR 3x to 5x at low light levels by reducing photon shot-noise
- ▶ Preserve signal intensities ensuring quantitative measurements
- ▶ Extend cell lifetimes with reduced phototoxicity and photobleaching
- ▶ Extremely useful for low light imaging applications dominated by noise

With the near-perfect sensitivity of Backside Illuminated Scientific CMOS sensors, the latest generation of scientific cameras have enabled imaging using only a few photons per pixel. Unfortunately, these minute signals are dominated by the natural Poisson variation in light levels preventing useful quantitation.

PrimeEnhance uses a quantitative SNR enhancement algorithm used in Life Science imaging to reduce the impact of photon shot-noise present in acquired images, leading to an increase in Signal to Noise Ratio (SNR) by 3x to 5x with equivalent exposure times.

With PrimeEnhance, the exposure times can be reduced by a factor of 8-10X while maintaining the Signal to Noise ratio. This reduces the effects of cellular photo-damage and extends cell lifetimes.

Invented at INRIA and further optimized for fluorescence microscopy at the Institut Curie, the denoising algorithm used in PrimeEnhance uses a patch based evaluation of image data and knowledge of the each individual camera's performance parameters to reduce the effects of photon shot-noise. The patches of image intensities and their noise characteristics are processed and evaluated with increasing neighborhood sizes during which weighted intensity averages are taken. This iterative process preserves not only the quantitative nature of the measured intensities, but also the maintains the finer features present in biological samples.

Detailed performance and methodology of the algorithm is available in the following publication:
Patch-based nonlocal functional for denoising fluorescence microscopy image sequences.
 Boulanger J, Kervrann C, Boutheimy P, Elbau P, Sibarita JB, Salamero J. *IEEE Trans. Med Imaging* 2010 Feb.

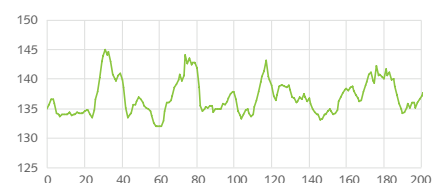
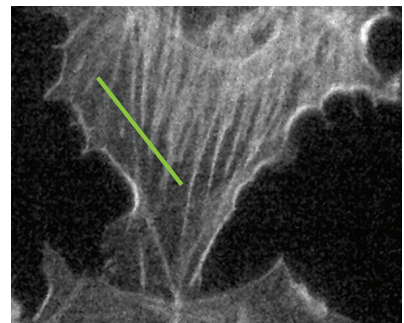
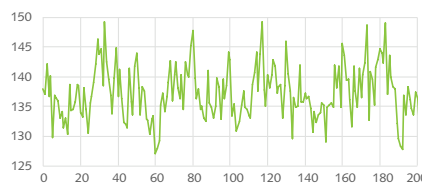
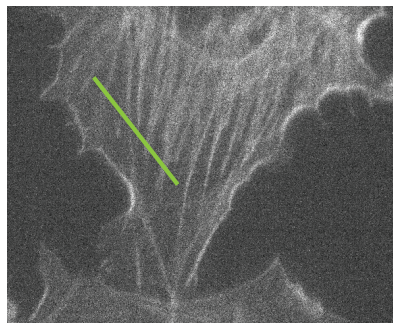

Embedded Signal Processing (ESP™) Features

PrimeLocate

Localization based super-resolution microscopy requires a sparsity of data to ensure proper localization of emitting molecules. Even with this sparsity, the full image frame is transferred to the host to be analyzed, creating a large amount of data to be processed without adding useful information.

PrimeLocate dynamically evaluates image data and locates 500 regions per frame containing single molecule data relevant for super-resolution localization. Only these 500 regions are transferred to the host computer, drastically reducing the amount of data and time required for analysis.

By transferring only the relevant raw data, users have the freedom to use their preferred localization algorithm to generate super-resolution images.

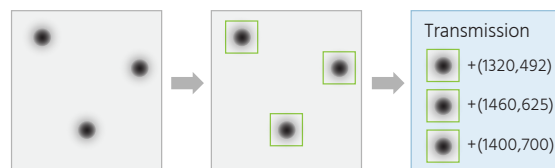

- ▶ Only the data within the patches is transferred to the host computer
- ▶ Processing time and storage requirements are easier to manage with the acquisition of only relevant data
- ▶ Ability to transfer 500 regions per frame
- ▶ Allows freedom to select preferred super-resolution localization algorithm

Multi-ROI

The surplus of data generated by sCMOS devices is challenging to acquire, analyze, and store, requiring special interfaces and expensive SSDs. While a large Field of View (FOV) is convenient for imaging, at times, only certain areas contain the desired information.

Multi-ROI allows users to select up to 15 unique ROIs within the FOV, and only these selected regions are transferred to the host computer. This allows for a large reduction in the amount of data acquired but ensures that the critical information is obtained.

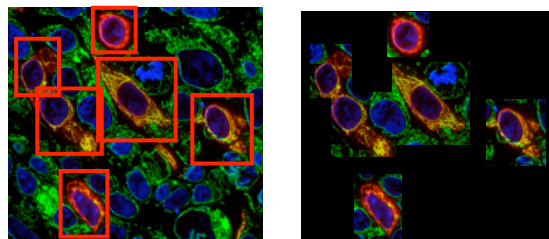

- ▶ Only the data within the user-defined ROIs is transferred to the host computer
- ▶ Select up to 15 unique regions
- ▶ Significantly reduce the amount of data being acquired

Specifications	Camera Performance
Sensor	Gpixel GSENSE2020BSI Scientific CMOS sensor
Active Array Size	2048 x 2048 (4.2 Megapixel)
Pixel Area	6.5µm x 6.5µm (42.25µm ²)
Sensor Area	13.3mm x 13.3mm 18.8mm diagonal
Peak QE%	>95%
Read Noise	1.1e- (Median) 1.3e- (RMS)
Full-Well Capacity	45,000e- (Combined Gain)
Dynamic Range	41,000:1 (Combined Gain)
Bit Depth	16-bit (Combined Gain)
Readout Mode	Rolling Shutter Effective Global Shutter
Binning	2x2 (on FPGA)

Cooling Performance	Sensor Temperature	Dark Current
Air Cooled	-10°C @ 30°C Ambient	0.5e-/pixel/second
Liquid Cooled	-25°C @ 30°C Ambient	0.12e-/pixel/second

Specifications	Camera Interface
Digital Interface	PCIe, USB 3.0
Lens Interface	C-Mount
Mounting Points	2 x ¼ 20" mounting points per side to prevent rotation
Liquid Cooling	Quick Disconnect Ports

Triggering Mode	Function
Input Trigger Modes	Trigger-First: Sequence triggered on first rising edge Edge: Each frame triggered on rising edge SMART Streaming: Fast iteration through multiple exposure times
Output Trigger Modes	Any Row: Expose signal is high while any row is acquiring data Rolling Shutter: Effective Global Shutter – Expose signal is high when all rows are acquiring data Signal is High for set Exposure time – Readout Time
Output Trigger Signals	Expose Out (up to four signals), Read Out, Trigger Ready

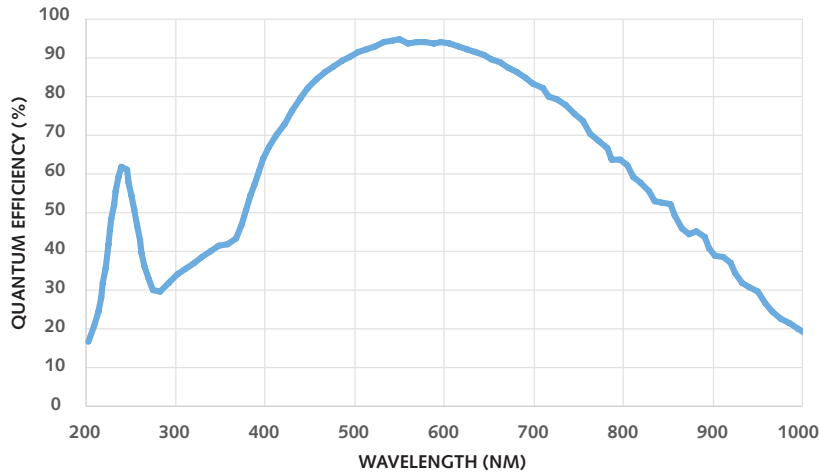

Frame Rate		
Array Size	16-bit	11-bit*
2048 x 2048	43.5	87
2048 x 1024	87	174
2048 x 512	174	348
2048 x 128	696	1392

*When Available

Accessories (Included)	
USB 3.0 Cable	Manual
Trigger Cable	QuickStart Guide
Power Supply	

Accessories (Additional)
PCIe Card/Cable
Liquid Circulator
Liquid Cooling Tubes

Distance from C-mount to sensor

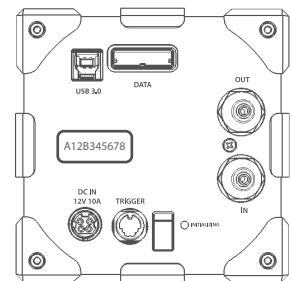
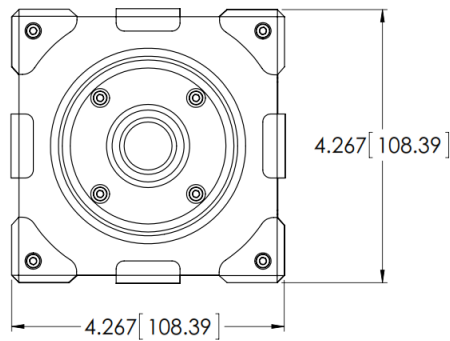
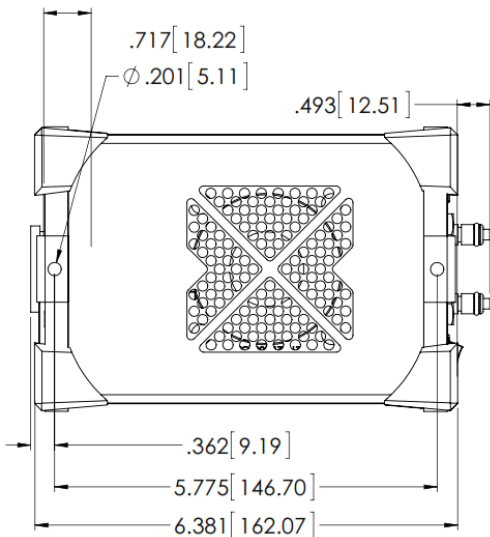

Photometrics is a registered trademark.
 Prime BSI is a trademark of Photometrics.
 All other brand and product names are the trademarks of their respective owners.

Specifications in this datasheet are subject to change.

Refer to the Photometrics website for most current specifications.

PHOTOMETRICS
www.photometrics.com
 info@photometrics.com
 tel: +1 520.889.9933